

PARLOR

MINI CHARM PROJECT

© 2025 moda fabrics • all rights reserved

SUPPLY REQUIREMENTS

11960MC	1 Parlor Mini Charm Pack
BACKGROUND (9900-182)	1/2 yard
PILLOW BACKING FABRIC	3/8 yard
MUSLIN	3/4 yard or (1) 20" x 20" and (2) 13" x 20" light scrap fabric
BATTING	3/4 yard or (1) 20" x 20" and (2) 13" x 20" scrap pieces
BINDING	1/4 yard
1 - 18" PILLOW FORM	

CUTTING INSTRUCTIONS

Background	1 – 2" x WOF. Subcut: (2) 2" x 19 1/2" rectangles
	5 – 2 1/2" x WOF. Subcut: (4) 2 1/2 x 10" rectangles (4) 2 1/2 x 8" rectangles (4) 2 1/2 x 6" rectangles (4) 2 1/2 x 4" rectangles (24) 2 1/2" squares
Backing Fabric	2 – 12 1/2" x 19 1/2" rectangles
Binding	3 – 2 1/2" x WOF strips
Muslin	1 – 20" x 20" and 2 – 13" x 20"
Batting	1 – 20" x 20" and 2 – 13" x 20"

- All piecing seam allowances are 1/4".
- Press seams open unless stated otherwise.



BOHO GEM PILLOW COVER

FINISHED SIZE 18" x 18"



FEATURING PARLOR BY CRYSTAL MANNING



PIECING INSTRUCTIONS

HALF SQUARE TRIANGLES (HST)

1. Gather (24) 2 ½" squares and (24) 2 ½" Background squares. On the wrong side of the Background squares, draw a diagonal line from corner to corner.

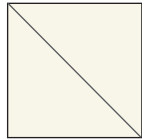

2. Pair (1) Print square with (1) Background square, Right Sides Together (RST).

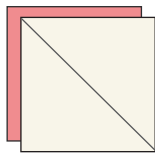

3. Stitch on the marked line.

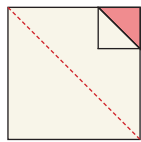

4. Trim ¼" from the diagonal line on one side. Press seams open.

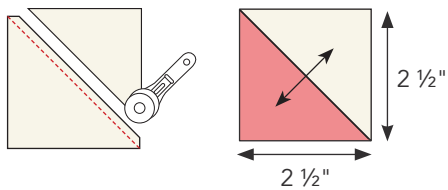

5. Repeat steps 1 - 4 to make (24) HSTs total.

FLYING GEESE

6. Gather (20) 2 ½" HSTs. Pair two HSTs together and sew together to make a Flying Geese unit. Press seams open.

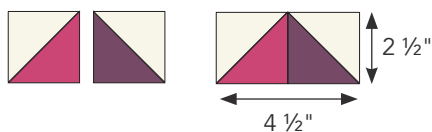

7. Repeat to make (10) Flying Geese units.

STITCH & FLIP STRIPS

8. Gather the (16) 2 ½" rectangles and (16) 2 ½" print squares. On the wrong side of the print squares, draw a diagonal line from corner to corner to use as a sewing guide.

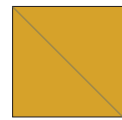

9. Align one print square with the edge of a 2 ½" x 10" rectangle, RST. Stitch on the marked line. Trim seam allowance to ¼". Flip the top triangle away from the bottom piece and press to the corner.

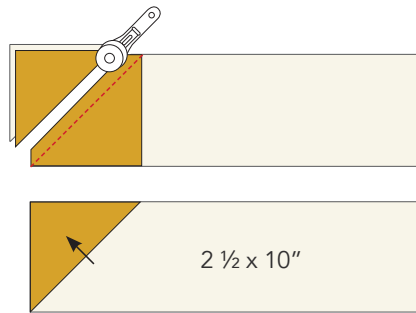

10. Repeat steps 8-9 for all 2 ½" strips. Refer the diagram below for the correct orientation and strip length.

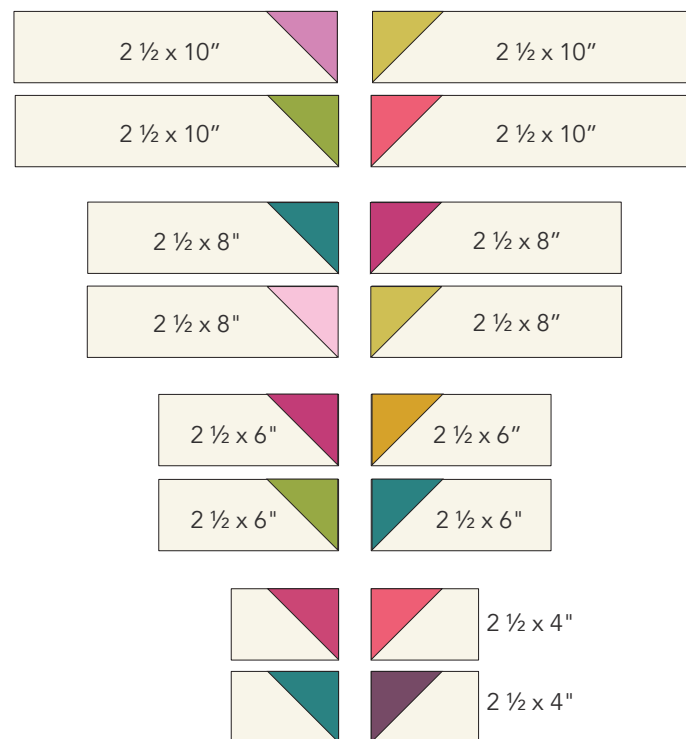

PILLOW TOP ASSEMBLY

11. Referring to the **Pillow Top Assembly Diagram**, layout all pieced units and background strips. Sew the units together to form rows. Join the rows together and press seams open. The unfinished pillow top should measure 19 ½" square.

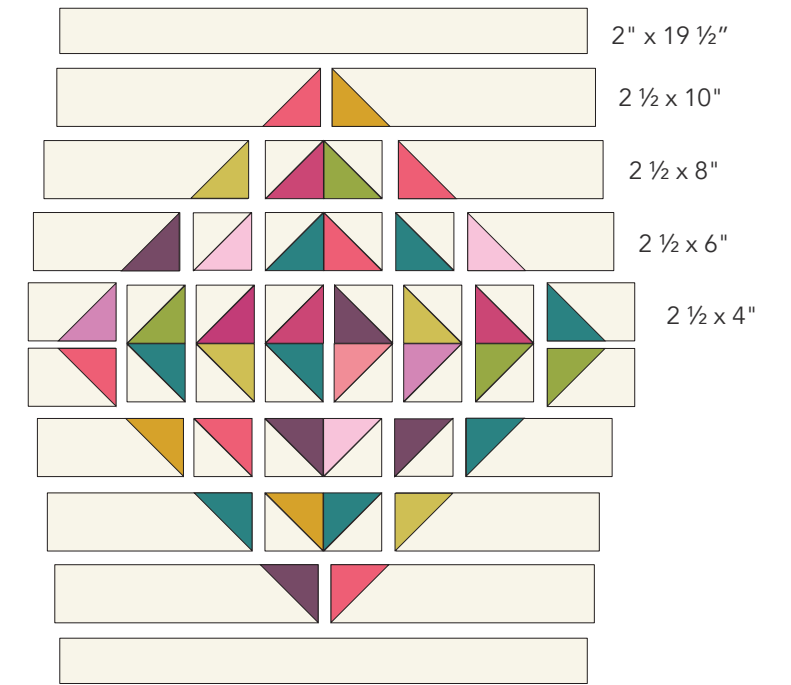

FINISHING THE PILLOW COVER

BINDING

12. Join the (3) 2 ½" binding fabric strips together end to end using a diagonal seam to make one long strip.

QUILT THE PILLOW TOP AND BACK PIECES

13. Create a quilt sandwich with the batting between the pillow top and the muslin.

14. Quilt as desired. When quilting is complete, square your pillow top by trimming off excess batting and muslin. It should measure 18 ½" square.

15. Repeat steps 13 -14 to quilt the (2) 12 ½" x 19 ½" pillow back pieces. Trim the pieces to 11 ½" x 18 ½".

PILLOW CONSTRUCTION

16. Sew the binding to one 18 ½" edge on each backing piece. These edges will form the envelope closure.

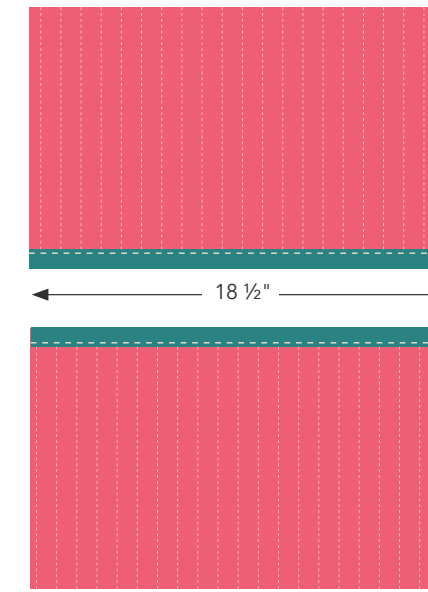

QUILTED PILLOW BACK PIECES

17. Overlap the pillow back pieces with the binding edges by 4" to make an 18 ½" square. With a scant ¼" seam allowance, stitch across overlaps to make the pillow back.

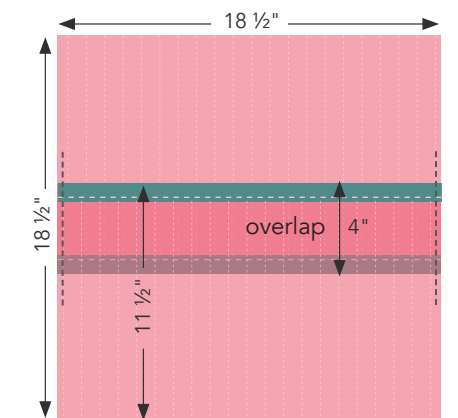

18. Layer the pillow top with the pillow back, Wrong Sides Together. Baste stitch a scant ¼" around the pillow to secure the layers.

19. Attach and finish the binding using your preferred method.